

Operatørbord 240x80cm

Produsent: IDT Solutions AS

Spesifikasjoner

Løfthøyde:	500 mm. 690-1190 mm. 2-delt.
Løfthøyde:	650 mm. 620-1260 mm. 3-delt.
Løftekraft:	150 kg.
Farge:	Alu RAL 9006, Sort RAL 9005.
Støynivå:	40 dB.
Betjening:	Bordkontroll.
Standby power:	0,1W.
Bordplate:	Mørk grå høytrykkslaminat med ABS kantlist.

IDT operatørbord med fast hylle for pc-skjermer.
Modellen leveres med kraftig sargsystem og asymmetriske føtter, noe som gjør at bordet tåler høy belastning.
Leveres med bordplate og brakett til fast hylle for pc-skjermer.

5 års garanti.

LINAK løftesøyler med soft/stopp funksjon.

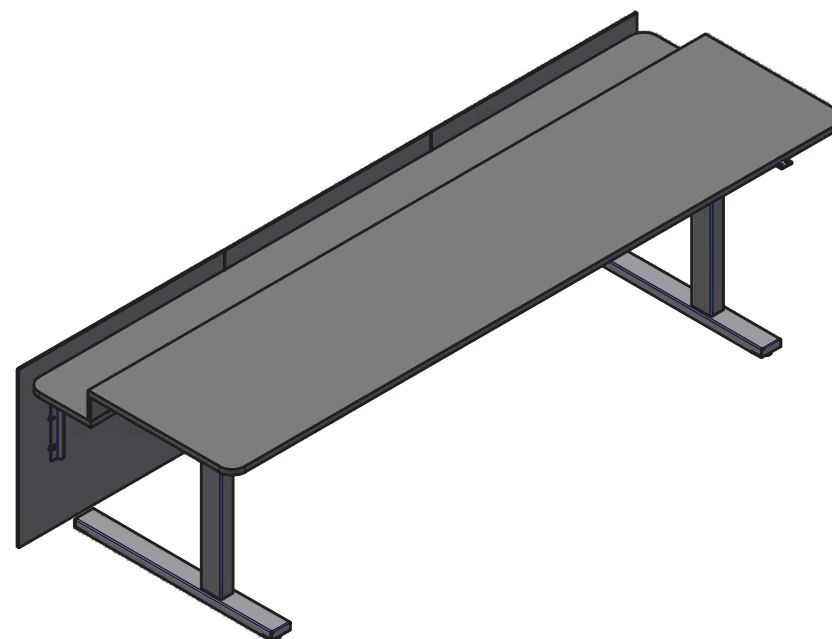



CERTIFICATE



Management System Certificate

To certify conformity with // Godkjent overensstemmelse med the Management System Requirements of // Styringssystemkravene i henhold til

NS-EN ISO 9001:2015
NS-EN ISO 14001:2015

awarded // tildelt



IDT Solutions AS
Lenagata 131, 2850 Lena

Manufacturing/supplying following products/services:
for produksjon/leveranse av følgende produkter/tjenester:

**Produksjon av egne produkter innen
elektro, møbel, sport og aluminiumsbehandling**

Certificate No // Sertifikat nr.:

517

First issued // Utstedt første gang: 2006-07-04
Last expiry // Forrige utløp: 2021-07-04
Last recertification // Siste resertifisering: 2021-05-19
Valid until // Gyldig til: 2024-07-04
Issued // Utstedt: 2021-06-11
Audit: Annual // Oppfølging: Årlig

Director Certification // Direktør Sertifisering

Nordic Swan Ecolabel Licence



Issued by:
Stiftelsen Miljømerking i Norge
Henrik Ibsens gate 20
NO-0255 Oslo, Norge

Details of licensee

Company name and address: IDT Solutions AS Lenagata 131 2850 Lena	Organisation number: 992951222 Phone: (incl. country code) +47 61 16 52 60 EAN:
Contact: Dag Arnesen	<input checked="" type="checkbox"/> Manufacturer <input type="checkbox"/> Reseller/importer
Manufacturer: IDT Solutions AS (produksjon) Place of manufacture: Øverskreien 155, 2848 Skreia, NORWAY	

Licence details

Licence number: 2031 0132	Licence version: 4.5	Valid thru: June 30, 2023
Criteria document: 031 Furniture and fitments 4		Validity: March 17, 2011 - June 30, 2023
Comments:		

Ecolabelled products:

Designation and specification of the product by country:

Norway	see appendix	Iceland	see appendix
Finland	see appendix	Sweden	see appendix
Denmark	see appendix	Outside the Nordic	see appendix

This licence is pan-Nordic and is valid in all Nordic countries.

The ecolabelling organisation hereby grants the above licensee the right to use the Nordic Ecolabel in accordance with the terms of the licence on or in conjunction with products that conform to the provisions of the relevant ecolabelling criteria or in conjunction with the marketing of products. The use of the ecolabel in other Nordic countries is included by this licence without separate registration. The turnover of the specified products shall once a year, on request, be reported to the ecolabelling organisation by 1 April at the latest. Turnover shall be broken down by Nordic country.

The ecolabelling organisation undertakes to inform licensees if any amendment is made to the criteria document.

The licence will be revoked with immediate effect if the "Regulations for Nordic Ecolabelling of products" or the ecolabelling criteria for the product group are disregarded. If the licensee causes the ecolabelling organisation direct or indirect costs as a result of this or if damage is caused by a product manufactured/sold by the licensee, the licensee shall indemnify the ecolabelling organisation in full. The ecolabelling licence is valid up to the specified date unless written notice of cancellation is issued by the licensee or the ecolabelling organisation at least three months in advance. The licence is non-transferable unless an application for transfer is submitted.

Oslo, Norge, July 02, 2022
Stiftelsen Miljømerking i Norge

.....

Cathrine Pia Lund
Managing Director

Kiwa AS,
Kabelgaten 2,
N-0580 Oslo

